

## Digalox DPM72-AVP Instruction manual (Rev-2018-03)

Visit [www.digalox.com](http://www.digalox.com) to download software “Digalox Manager”.

**Package contents:** Panel meter Digalox DPM72, 5x jumpers, 1x mounting bracket

### 1. Intended Use

- Indoor use non condensing, non corrosive.
- Panel mounting.
- Failure to comply with these instructions will void all guarantee and warranty.
- Preferred supply of USB devices via screw terminals with 10 to 24V AC/DC. Supply via USB in operation, USB supply voltage must be at least 5V.

### 2. Safety instructions

- **Note: the measurement inputs of the device can carry life-threatening voltages!**
- **When working on the device hazardous voltages must not be connected to the device!**
- **The device must not be used as the only protective device or protective shutdown.**
- Read instruction manual carefully before operating the device!
- The device is not intended to protect persons or facilities against harm. Specific devices must be used to guarantee safety (protection relais, off-switches, etc).
- When connecting switches to the terminals J1-J6 only switches must be used whose isolation voltage is at least twice the maximum occurring measurement voltage. For example, when measuring 250V AC switch must be isolated for at least 500V.
- Do not open the housing!
- Do not use the instrument in the presence of explosive or flammable substances!
- All cables carrying hazardous voltages must be secured with external separators.

### 3. Description

The measure modes volt AC/DC, ampere, frequency and 5A current transformer are supported. Scale endpoint of the indicator as well as scaling of the analogue signal and current transformer measurement can be adjusted freely via the DIP switch, alternatively there is an option for automatic adaption of the scale endpoint. The unit can be switched between volt and ampere measurement via an external switch. Minimum and maximum values are recorded and can be displayed optionally using an external switch. Measured values are recorded over a time span of 3 minutes up to 14 days. The time base as well as the display of the measuring history can be activated by an external switch.

The following parameters can be adjusted using the USB-Software: Scale-endpoint, scale-caption, display-style (pointer, tachometer, bar graph, and more), splash display, thresholds for alarm output, hysteresis, and more. Recorded measurement values can be read and a continuous transmission of the actual measuring value can be enabled. Using the software, values can be viewed and exported as CSV.

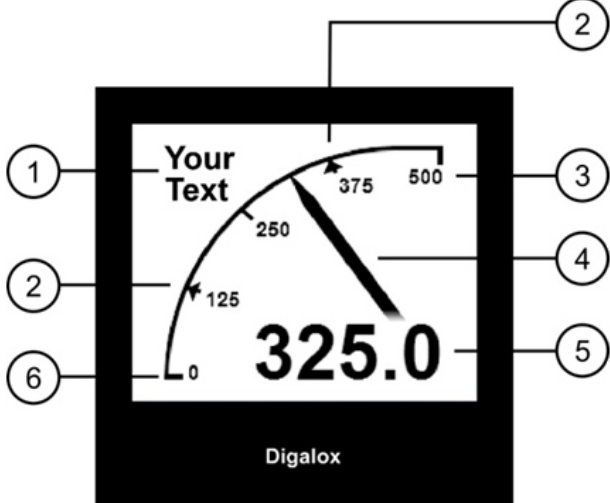
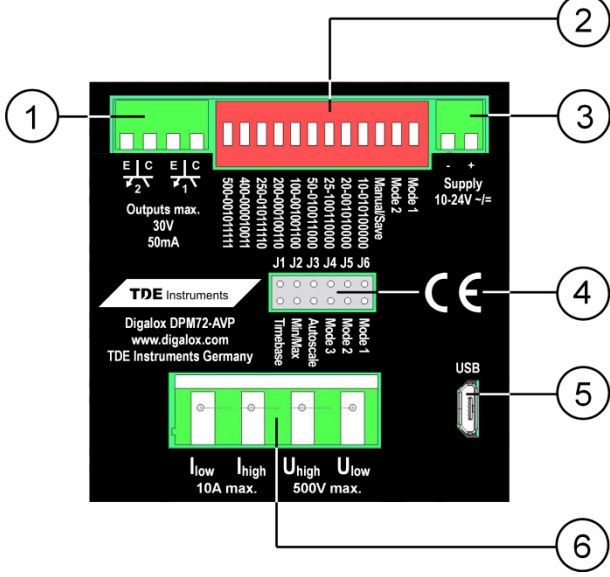
|                                                                                     |                                                                                                                                                                                                                                                                                                                                                                                                                                                                                                          |
|-------------------------------------------------------------------------------------|----------------------------------------------------------------------------------------------------------------------------------------------------------------------------------------------------------------------------------------------------------------------------------------------------------------------------------------------------------------------------------------------------------------------------------------------------------------------------------------------------------|
|   | <p><b>Front</b></p> <ol style="list-style-type: none"> <li>Unit or free text</li> <li>Threshold value</li> <li>Upper scale caption</li> <li>Graphical measurement display</li> <li>Digital measurement value</li> <li>Lower scale caption</li> </ol>                                                                                                                                                                                                                                                     |
|  | <p><b>Back</b></p> <ol style="list-style-type: none"> <li>2 optocoupler switch outputs</li> <li>DIP switch for setting measurement mode and upper scale caption</li> <li>Supply voltage input</li> <li>Jumpers for configuration or connection external switch for activating/switching measurement mode, graphical historic data display, min/max display, auto-scaling</li> <li>USB interface for alternative power supply and software communication interface</li> <li>Measurement inputs</li> </ol> |

## 4. Electrical Connections

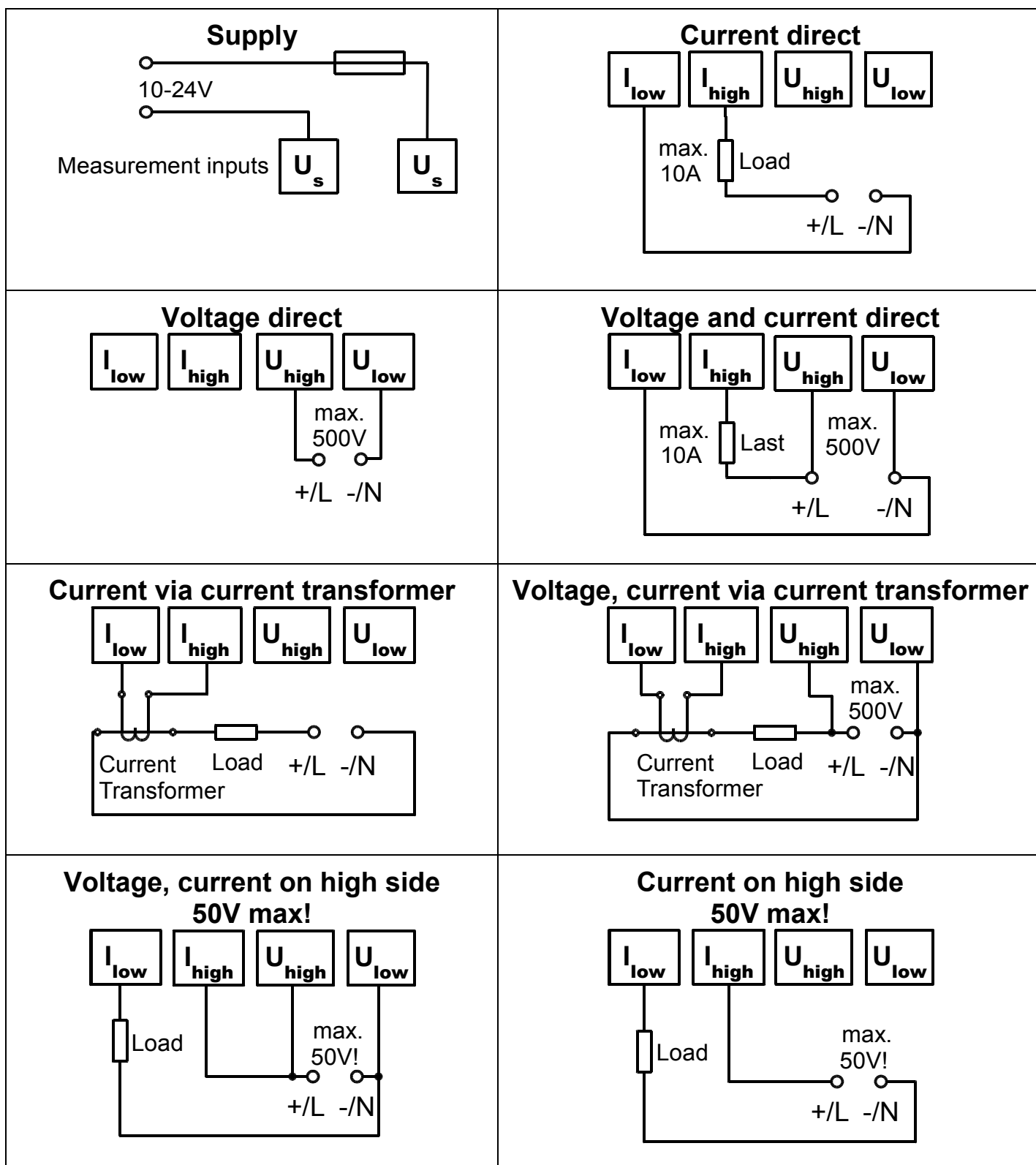

### Warning:

The device may only be operated in one of the connection options shown below!

Voltage measurement on the high side (between plus and load) is recommended only for voltages up to 50V!

In this case the entire device is on high potential. Particularly to be considered when connecting switches to JP1-6.

## 5. Configuration

The device can be configured via DIP switches and jumpers manually or with the corresponding software “Digalox Manager” via USB interface. When configuring via DIP switches and jumpers the basic settings can be made computer-independent. The configuration with the software “Digalox Manager” allows full functionality.

### Setting scale via DIP switch

In modes where a scaling is necessary to represent the correct measurement value (for example 5A AC for current transformer) the upper scale value corresponds to the primary value of the current transformer or shunt.

Example:

upper scale value = 50 = primary value of the current transformer

### Configuration via USB interface with software “Digalox Manager”

Visit [www.digalox.com](http://www.digalox.com) to download software “Digalox Manager”. For use with software set DIP switch 10 to OFF position.

Please note that the measuring mode selected in "Digalox Manager" is displayed only until the power supply of the DPM72 is interrupted.

**In further operation, the device always shows the measurement mode, which is set by the jumpers J4-J6 or the DIP switches 11-12 respectively! (see table "Measuring mode").**

### Configuration via DIP switches and jumpers if only one measurement mode is required (Manual mode)

1. Set DIP switch 10 to ON position.
2. Set measurement mode with jumpers at J4-J6 according to table "Measurement mode", column "Manual mode".
3. Set upper scale caption for the first measurement mode with DIP switches 1-9 (see “Configuration of the upper scale caption”).
4. Connect supply voltage.

## **Configuration via DIP switches and jumpers if it is required to switch between multiple measurement modes via an external switch (Save mode)**

The required measurement modes are configured and saved sequentially.

1. Connect supply voltage.
2. Set DIP-switch 10, 11 and 12 to OFF position.
3. Set the measurement mode with jumpers at J4-J6 according to table "Measurement mode", column "Save mode".
4. Set DIP switch 10 to ON position.
5. Set upper scale caption for the first measurement mode with DIP switches 1-9 (see "Configuration of the upper scale caption").
6. Set time base for graphical historic data display (optional, see "Other settings").
7. Set DIP switch 10 to OFF position.
8. "Saved" appears on the display. The configuration of the first measurement mode is now completed.
9. When using multiple measurement modes repeat steps 2-8 until all required measurement modes are configured. The time base must not be set again, as it is used for all measurement modes.
10. In operation the measuring modes can be changed with a switch at J4-J6 according to table "Measurement mode", column "Save mode".

## **Configuration of the upper scale caption**

The upper scale caption is binary coded using DIP switches 1-9. Possible values are 1 to 500. Switch 1 corresponds to 256, switch 2 corresponds to 128, switch 3 corresponds to 64, etc., switch 9 corresponds to 1. For configuration, proceed as follows:

1. Connect supply voltage.
2. Set DIP switch 10 to ON Position.
3. Set DIP switches 1-9 to OFF position.
4. Start with 1st switch.
5. Set switch to ON position.
6. If the displayed value is greater than the desired value, set the switch back to OFF position.
7. If the displayed value is less than the desired value, leave switch to ON position and move on to the next switch.
8. Repeat steps 5 to 7 until desired value is displayed.

## Table common switch combinations

| Value | Combination<br>(DIP switch 1-9) | Value | Combination<br>(DIP switch 1-9) | Value | Combination<br>(DIP switch 1-9) |
|-------|---------------------------------|-------|---------------------------------|-------|---------------------------------|
| 10    |                                 | 50    |                                 | 200   |                                 |
| 20    |                                 | 100   |                                 | 250   |                                 |
| 25    |                                 | 150   |                                 | 500   |                                 |

## Table measurement mode

| Measurement mode                      | Display      | Scale               | Manual mode | Save mode |
|---------------------------------------|--------------|---------------------|-------------|-----------|
| V AC direct                           | Volt AC      |                     |             |           |
| A AC direct                           | Ampere AC    |                     |             |           |
| V DC direct                           | Volt DC      |                     |             |           |
| A DC direct                           | Ampere DC    |                     |             |           |
| AC Frequency                          | Frequency Hz |                     |             |           |
| 5A AC scaled<br>(Current transformer) | Ampere CT    | Upper scale caption |             |           |
| 1A AC scaled<br>(Current transformer) | Ampere CT    | Upper scale caption |             |           |

## 6. Other settings

The following functions can be activated independently by short-circuiting connectors J1-J3 by jumper or switch during operation:

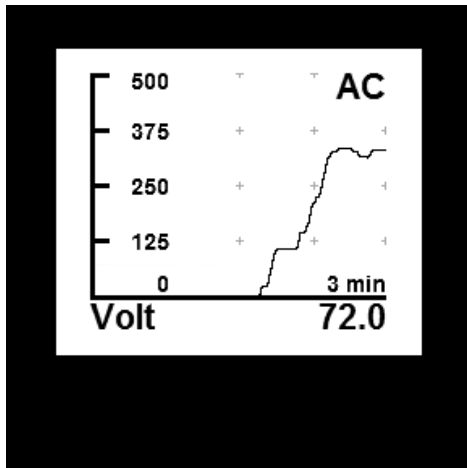

### J1: Graphical historic data display

To activate the graphical historic data display connector J1 is shorted. The unit displays the stored values within the set time base as a graphical trend.

The time base can be set to days (7, 14), hours (6, 12, 24, 48, 72) or minutes (3, 15, 30, 60).

The time base can be changed by alternatingly opening and closing J1 (interval < 2 sec). When first opening and closing J1 the current time base is displayed. For each subsequent opening and closing the time base changes to the next setting. In order to save the setting permanently, DIP switch 10 must be switched from ON to OFF position.

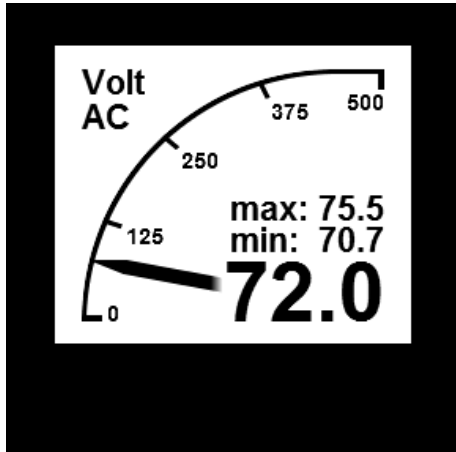

### J2: Min-Max-display

To activate the Min-Max display connector J2 is shorted. The display shows the maximum and minimum values recorded since the last reset. The values can be reset by opening and closing connection J2 shortly (interval < 2 sec). The display shows "minmax reset".

### J3: Auto-scaling

To activate auto-scaling J3 connector is shorted. The device automatically changes the upper scale caption depending on the current measuring value in steps of 10, 100 and the set of top scale caption.

## 7. Mounting

Carefully insert the instrument into the panel cutout. Insert the mounting bracket from the back and push towards the panel until instrument sits tight. Make sure the mounting bracket is snapped into the side of the housing. To ensure IP65 protection (dust and water jet) when mounting in a front panel, use optional gasket.

## 8. Specifications

|                             | <b>DPM72-AVP</b>                                         |
|-----------------------------|----------------------------------------------------------|
| Supply                      | 10-24V AC/DC or via USB (min. 5V), galvanically isolated |
| Display                     | LCD graphic display 192x160 Pixel                        |
| Measuring range voltage     | ± 500V AC/DC                                             |
| Accuracy voltage            | 1%                                                       |
| Internal resistance voltage | 2,6MΩ                                                    |
| Measuring range ampere      | ± 10A AC/DC and 5A AC CT                                 |
| Accuracy ampere             | 1%                                                       |
| Internal resistance voltage | 5mΩ                                                      |
| Measuring range frequency   | 10-500Hz                                                 |
| Accuracy frequency          | 0,1Hz                                                    |
| Recording of measurement    | 3 mins. to 14 days                                       |
| Alarm outputs               | 2 optocouple outputs max. 30V DC, 50mA                   |
| Operating temperature       | 0°C to +50°C                                             |
| Storage temperature         | -20°C to +70°C                                           |
| Front panel                 | 72 mm x 72 mm                                            |
| Panel cut out               | 68 mm x 68 mm                                            |
| Protection front            | IP65 from the front                                      |

## 9. Cleaning

Observe the safety instructions before cleaning the instrument. Clean instrument with a dry lint-free soft cloth. Do not use solvents.

## 10. Contact Information

TDE Instruments GmbH, Gewerbestraße 8, D-71144 Steinenbronn

phone: +49 7157-20801

E-Mail: [info@tde-instruments.de](mailto:info@tde-instruments.de)

Internet: [www.tde-instruments.de](http://www.tde-instruments.de), [www.digalox.com](http://www.digalox.com)